

## CHAPTER 4

# HANDLING AND PRESERVING THE CATCH

- A. *The basics and the tools needed*
- B. *Landing, killing and bleeding the catch*
- C. *Dressing sashimi tuna ready for chilling*
- D. *Dressing swordfish ready for chilling*
- E. *Dressing and loining albacore ready for freezing*
- F. *Onboard preservation: icing the catch*
- G. *Onboard preservation: CSW and RSW*
- H. *Onboard preservation: freezing*
- I. *Cleaning and sanitising*

## INTRODUCTION

This chapter describes the handling and processing side of horizontal tuna longline fishing activity, with a focus on producing a high quality export product. The basic tools needed for handling and processing the catch on board the vessel are described. The method of using the tools to kill and bleed the catch, and the methods of processing tunas and broadbill swordfish for chilling, or further processing for freezing are then described. The different forms of chilling mediums are covered with a description of their use and how to preserve the catch using each. The final section looks at cleaning and sanitising the boat after each set and at the end of a fishing trip.

## A. THE BASICS AND THE TOOLS NEEDED

Most longline caught fish are either retained whole (nothing done to the fish), or dressed in some way with parts of the fish removed. Dressed fish that have the gills and guts removed are called gilled and gutted, or G&G. Fish that have the heads and guts removed are called headed and gutted, or H&G. Fish can also be finned. That means all fins have been removed. A fully dressed fish is H&G and finned. Fish can also be cut or loined — half-loined or quarter-loined with pin bones in or out, belly flap on or off, and skin on or skin off. Loins are often called fillets.

Longline caught fish can be chilled fresh, or frozen. Frozen whole albacore for the canneries are usually finned. Frozen cannery albacore or frozen albacore quarter-loins must be kept at  $-18^{\circ}\text{C}$  or below while on the vessel and during transport to canneries or markets. Frozen G&G sashimi grade tunas must be kept at  $-65^{\circ}\text{C}$  (ultra-low temperature or ULT). ULT freezing of sashimi grade tunas is mainly carried out by the distant water Asian fleets.

All chilled fresh fish, including sashimi grade tunas, must be kept below  $4.4^{\circ}\text{C}$  but must not be allowed to freeze. The ideal temperature for fresh chilled fish is  $0^{\circ}\text{C}$ . On ice boats, fish are usually held at  $0^{\circ}\text{C}$  as that is the temperature of the melt ice surrounding the fish (Chapter 4 F). Fish kept in chilled or refrigerated seawater (CSW or RSW — Chapter 4 G) are usually at a temperature slightly below  $0^{\circ}\text{C}$ . An ice and seawater mixture has a lower temperature than a mixture of ice and fresh water. A typical RSW temperature would be about  $-0.5^{\circ}$  to  $-1.0^{\circ}\text{C}$ .

Tunas destined for sashimi markets require more care than other fish. Tunas are graded on size, colour, freshness and fat content. In addition, tunas are graded on general appearance and condition. Fish can be downgraded for gaff or meat hook marks on the body, scale loss, skin damage, bruising, bending, improper bleeding, and improper cleaning. Fish should be gaffed in the head, not in the body, and then landed gently on to a padded surface. Sashimi tuna should be stunned, spiked, double spiked with a *taniguchi* tool, bled, gilled and gutted, washed and trimmed, wrapped in mutton cloth and chilled. All of this should be done within ten to fifteen minutes of landing the fish. Tunas that are not handled properly may suffer from burnt tuna syndrome, or BTS. The Japanese call this *yake-niku*. Burnt tunas have no value as sashimi.

### Tools for handling fish

Before hauling starts, the deck should be laid out properly with all the tools and gear necessary for handling fish. The tools needed include: gaffs, fish bat, spike, *taniguchi* tools, knives, meat saw, meat hook, nylon brush, seawater hose, carpet or pad, gloves, and mutton cloth or plastic body bags.

**Gaffs:** there is a range of gaff heads available. One of the most popular is the Mustad gaff. The gaff head is attached to a pole of a suitable length for the boat it is being used from.



**Tuna missile:** is used to land large tuna. The missile is attached to a heavy line and runs down the leader where it clamps onto the tuna's head when it hits. The fish is then hauled up using the heavy line.

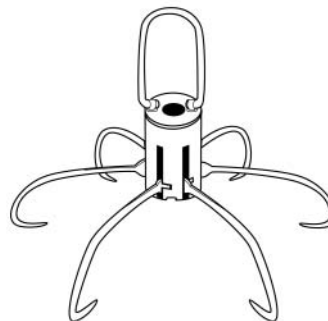

**Fish bat or club:** is used to stun the fish when it is landed. Commercial models in aluminium are available, although a piece of rounded wood with no sharp edges can also be used.



**Spike:** is used to destroy the brain of the fish after it has been stunned. A spike with a handle is easier and safer to use.

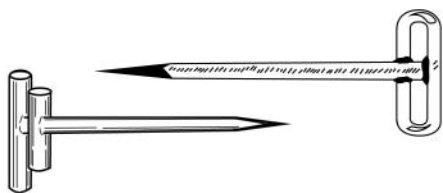

**Knives:** come in many shapes and sizes, and it is up to the individual as to which shape is preferred. A drop blood knife can be used for bleeding tuna. Other knives are used for cleaning and processing.

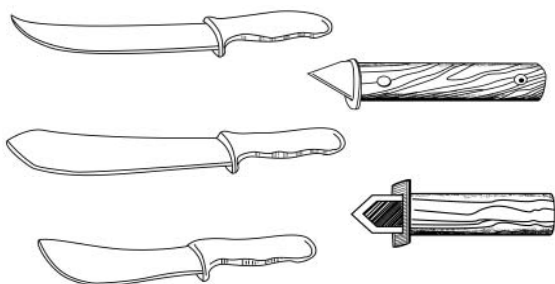

**Nylon brushes:** come in many shapes and sizes. Some are used for cleaning out the head cavity of G&G fish. Others are used for cleaning the boat at the end of each hauling session.



**Mutton cloth or plastic body bags:** are used to cover fish that are being placed in CSW or RSW, to minimise damage to the outside of the fish.

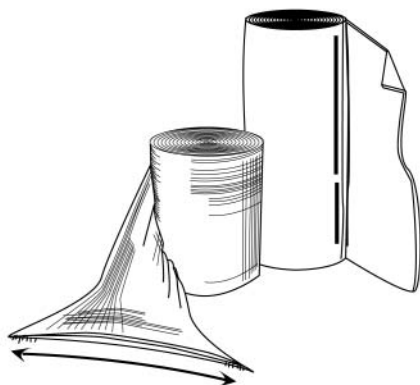

**Ice shovel:** is used on ice boats to bury fish when they are being packed in the ice hold.

**Taniguchi tool:** is inserted into the hole where the spike was inserted, and pushed down the neural canal. Taniguchi tools can be made from discarded monofilament mainline.

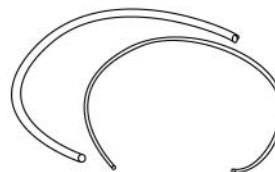

**Meat saw:** is used to remove the head or bill of swordfish and marlin, plus it can be used for cutting fins off larger fish.



**Meat hook:** is used to assist in landing fish and for moving fish around the deck or in the fish hold.

**Gloves:** are used by everyone on deck during hauling, especially those handling fish. A range of gloves are available.

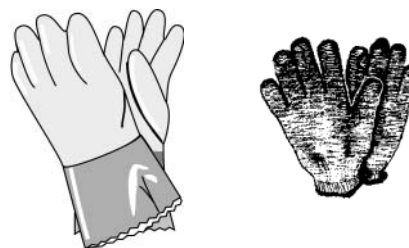

**Detergent and bleach:** are used for cleaning up the work area at the end of each trip. They are also used to wash out the fish holds after the fish have been offloaded.

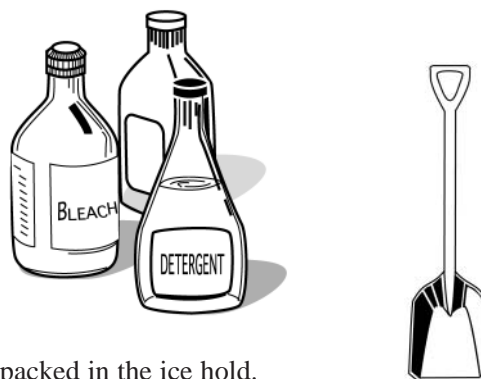

## B. LANDING, KILLING AND BLEEDING THE CATCH

When a fish comes up on the longline, it needs to be gaffed and lifted on board without damaging it. The fish should then be killed and bled, especially sashimi tuna, before it is processed ready for chilling. This section is based on the SPC manual ‘*On-board handling of sashimi-grade tuna — a practical guide for crew members*’.

### Gaffing

All fish, especially tunas and swordfish, should be gaffed in the head, never in the body. Two gaffs should be used on larger fish. The second gaff should be in the mouth. The heart and throat should not be gaffed. The heart will keep beating after the fish has been spiked. This will help get all of the blood out.

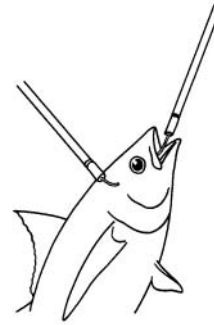

The throat should not be damaged on tunas as they will lose their shape and the meat will gape if the isthmus is broken. Gaping is when the layers of muscle in the flesh separate. If the isthmus does break loose from the jaw, it should be re-attached with a small piece of scrap monofilament line before the fish is chilled.

Tunas and swordfish should always be landed on a padded surface, never directly on the deck. The padding can be old carpet, foam mattress pads, soft rubber sheets, or burlap sacks. Landing the fish on a padded surface prevents bruising and scale loss. The crew handling fish should wear protective clothing and cotton or nylon gloves. Bare hands can leave oily handprints on a fish.

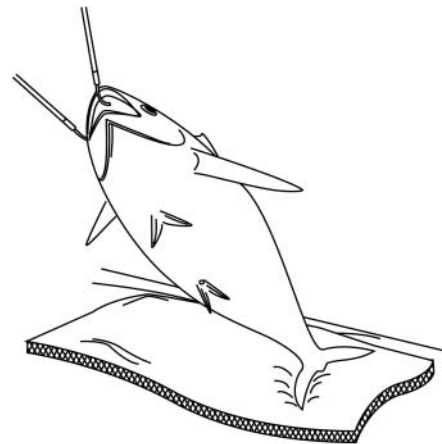

If small hand gaffs or meat hooks are used to move fish around on deck or in the fish hold, care should be taken to gaff only the head or the caudal keel, never the body. All tools used in landing and processing fish should be clean.

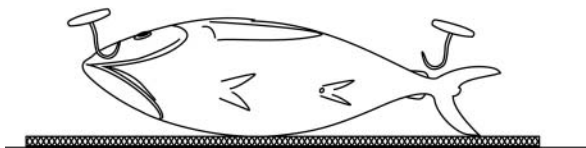

### Spiking and taniguchi

After gaffing and landing, if a fish is active, it should be stunned with a blow to the head by a fish bat, just between the eyes. This only knocks the fish unconscious and does not kill it. Often a fish can be calmed before spiking by covering its eye with a gloved hand.

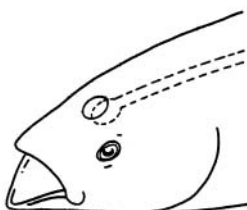
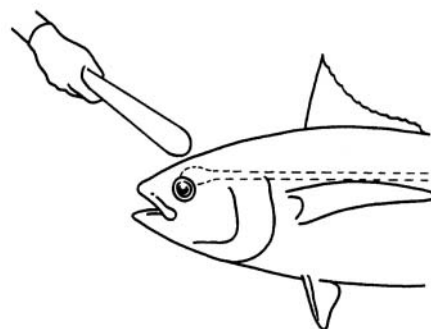

The nervous system of tunas must be destroyed by spiking and by using a *taniguchi* tool. Destruction of the nervous system prevents muscle movement and prevents BTS, where the flesh burns or turns brown. Spiking destroys the brain. The brain can be located on a tuna by looking for the soft spot on the head, just between the eyes when looking straight down on the fish. It will appear as a pale whitish spot. If the soft spot is not visible, it can also be found by rubbing the thumb over the head just between the eyes to feel it.

The fish should be held in an upright position and should be straddled by the person doing the spiking. The spike should enter the soft spot and be pushed back into the brain at a 45° angle. The fish will quiver and the jaw will go slack when it dies. This only kills the brain.

The spinal cord also has to be destroyed. This is done with a *taniguchi* tool, which is made from a 1 m long piece of 2.0 to 3.5 mm monofilament or stainless steel wire (reusable). The *taniguchi* tool is inserted into the hole left by the spike and pushed toward the tail. As it

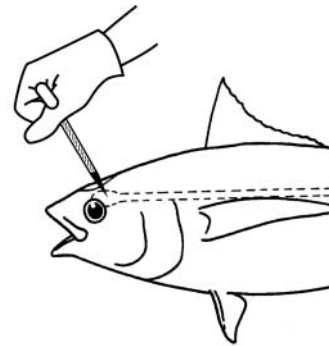
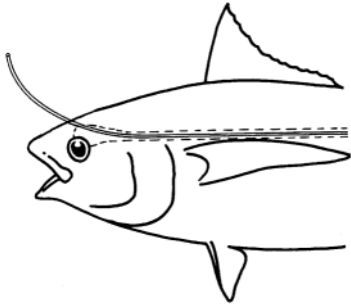

enters the spinal cord the body of the tuna will twitch, indicating that the nerves are being destroyed. The monofilament should be left in the fish with about 2 cm sticking out. Buyers prefer to see the monofilament as they know the fish was *taniguchied*; this method is also called *shime shime* in Japan.

### Bleeding

To preserve freshness it is also important to remove as much blood as possible from the fish before chilling. Tunas can be bled by cutting the blood vessels that lie under the pectoral fin recess on either side. A vertical cut about 2 cm deep should be made 6 cm (three fingers) back from the pectoral fin. This should be done on both sides of the fish. A drop blood knife is useful for this.

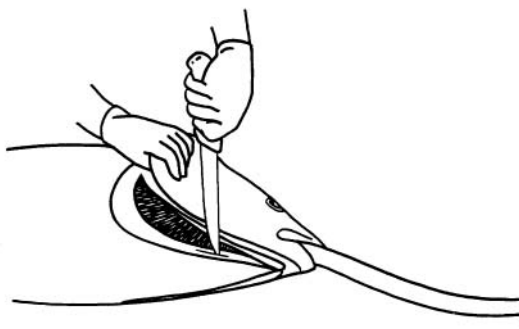
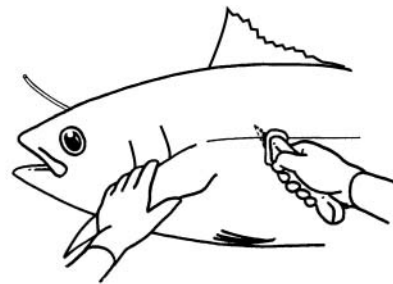

A seawater hose inserted into a cut in the gill membrane will flush the blood out. Alternatively, make cuts on either side of the throat, just in front of the heart, severing the arteries that go from the heart to the gills, and use a seawater hose stuck in the mouth to rinse all of the blood away. If fish are going to be chilled in CSW or RSW it is better to use the throat cut, as seawater could enter the side cut and damage some of the flesh when the fish is immersed in seawater. Bleeding takes five to ten minutes.

Albacore tuna are usually stunned with the fish bat and spiked to kill the brain, but are not *taniguchied*. They are also bled, usually with side cuts under the pectoral fins.

Swordfish are stunned with a fish bat if they are alive, although mostly they are dead when pulled in. If a swordfish is alive it is spiked, but not *taniguchied* and bled. Swordfish flesh is mainly consumed cooked.

Other byproduct species are usually stunned on capture, and depending on the species, spiked and bled, but not *taniguchied*.

### C. DRESSING SASHIMI TUNA READY FOR CHILLING

Once a sashimi tuna is spiked and bled, it should be dressed ready for chilling. Make a cut all the way around the gill membrane, cutting all gill attachments to the head. Then make a cut around the anal opening. (Alternatively, a cut can be made in the belly to within 1 cm of the anus and the intestines cut free of the anus.)

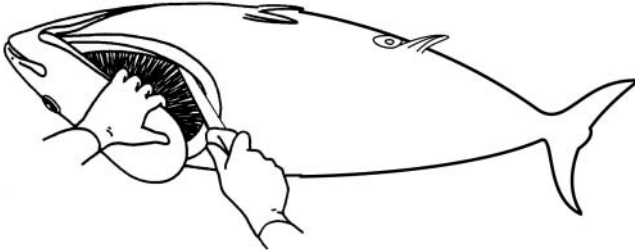

*Cut around gill membrane and anal opening*

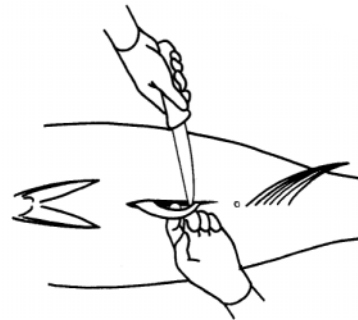

*Alternative belly cut*

The gills and guts can now be removed through the gill cover in one piece. The swim bladder and the gonads should be left in the gut cavity. Some fish graders like to look at the gonads to determine the sex and stage of sexual maturity of the fish.

The inside of the head cavity should then be trimmed of all loose tissue, the blood and kidneys and any gill membranes removed.

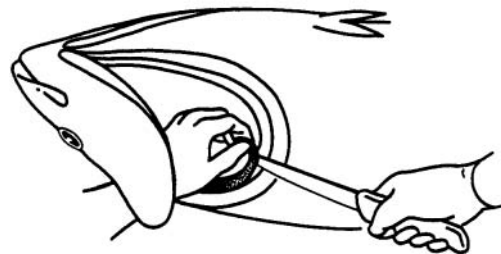

All remaining blood and kidney should be scrubbed from the base of the skull using seawater and a nylon brush. It is not necessary to scrub the gut cavity, and the outside of the fish should never be scrubbed.

The gut cavity and body are then rinsed with seawater to remove all blood and slime, and the fish chilled immediately. If a CSW or RSW system is used for chilling, the fish should be put in a mutton cloth sock to protect the skin from chaffing.

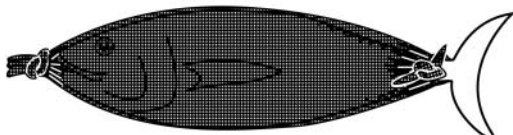
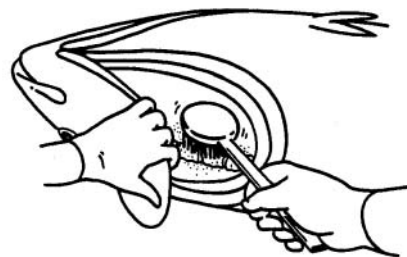

## D. DRESSING SWORDFISH READY FOR CHILLING

Dressing swordfish is quite different from dressing sashimi tunas. The head and all fins are removed. The head is removed with a meat saw, cutting right through the second gill cover at a 90° angle to the trunk.

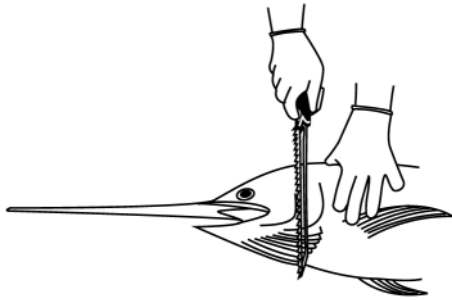

The remaining gill cover and gill arch membrane are removed with a sharp knife.

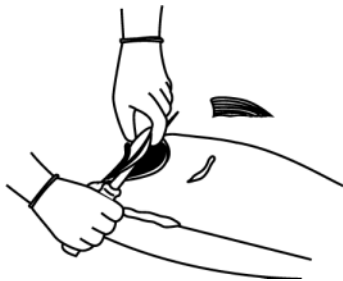

The guts are then removed, usually via the gill cavity area, and any loose tissue is removed.



The kidney and bloodvessels are cut away from along the spine and all blood is removed by thoroughly scrubbing and rinsing this area. White bone should show all along the length of the spine. All slime should be scraped away from the gut cavity with a large metal spoon or scraper and this area should be rinsed thoroughly.



Any visible parasites should be removed. The trunk should be wrapped in a plastic body bag before chilling.

Remove all fins and the tail (cut behind the caudal keel) using a knife or meat saw.

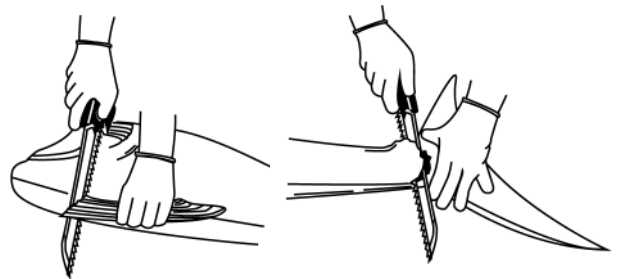

A cut is made around the anal opening and another cut made from here, forward up to but not through the pectoral girdle.

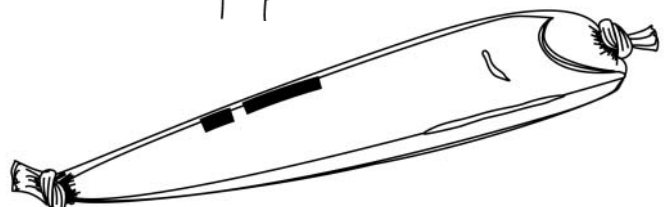
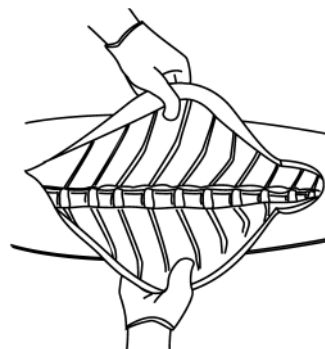
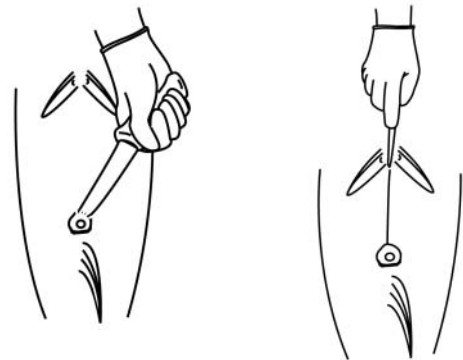

## E. DRESSING AND LOINING ALBACORE READY FOR FREEZING

In parts of the Pacific, albacore tuna make up the majority of the tuna catch, and they are targeted by fishermen in some areas. Albacore are mainly destined for the tuna canneries in the region, and they are delivered frozen. The fish can be frozen on board the boat, or landed chilled and then frozen in shore freezers before shipping to canneries. Other fish species besides albacore can be handled in this manner as well. Value-adding through loining (mainly albacore tuna) may be done before freezing. This can be done at sea or at shore facilities after the chilled catch is landed.

### Whole albacore

Preparing albacore tuna for freezing for canneries requires little processing. Some operators bleed the fish using a cut through the pectoral fin recess (Chapter 4 B), while others do not. Some boat operators do no processing, others cut the tail fins, and others remove both the tail and the pectoral fins. Fins are removed so the frozen fish stack better and take up less room in the freezer. The best approach is to check with the cannery to find out how they prefer the fish processed. The highest quality and highest value frozen albacore are bled first and then blast or plate frozen. These albacore are destined for sashimi markets in the US and Japan.

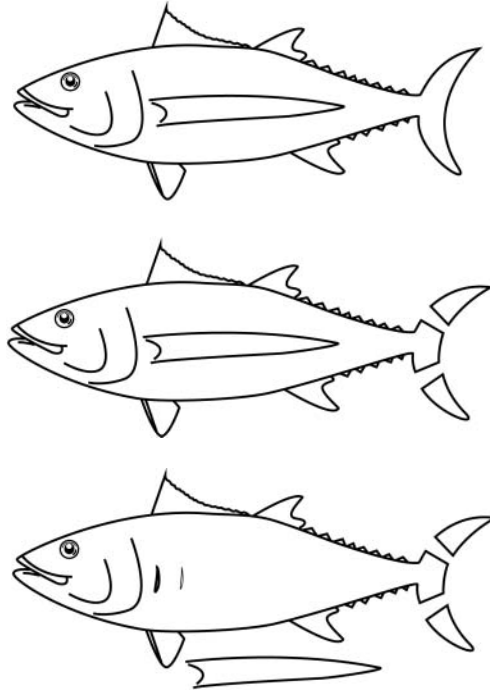

### Loining albacore

The term loining is used in two contexts in tuna fisheries. At a cannery, the first part of processing tuna is called loining: the fish are cooked, and the four loins are then separated from the skin and bones of the fish. These cooked loins are then canned.

The second context, and the one covered in this section, is the loining of fresh or uncooked fish. The loins are frozen at sea and are marketed for steaks or for sashimi. To do this the boat should be equipped with a processing room, and if the fish are to be exported, standards need to be adhered to for different markets (Chapter 5 A). The following method is used to produce processed albacore quarter-loins at sea ready for freezing.

Soon after the fish are caught they are bled and headed and gutted (H&G). This is usually done on deck with four cuts to remove the head (it can also be done in the processing room) using a large serrated knife. The first cut is made from under the pelvic fins towards the head at a 45° angle. The same cut is then made from under the pectoral fin on each side. Last is a chopping cut from the top of the head to the spine, with the head snapped away from the backbone by pulling on one of the pectoral fins.

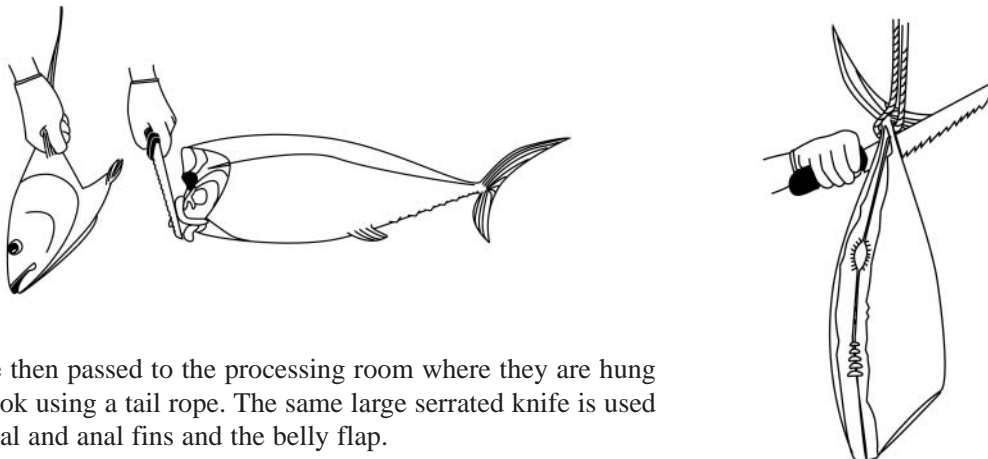

The H&G fish are then passed to the processing room where they are hung by the tail on a hook using a tail rope. The same large serrated knife is used to remove all dorsal and anal fins and the belly flap.

A filleting knife is then used to cut the flesh away from the frame, down to the backbone dorsally and ventrally on both sides of the fish. Care is taken to ensure the cut is as close to the frame as possible.

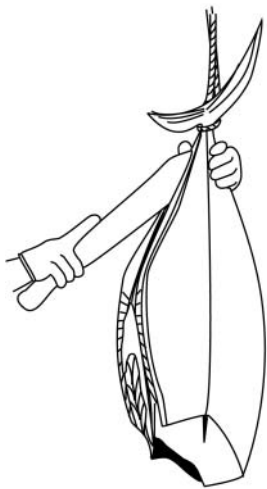

A meat hook is inserted into the tail end of the half-loin just in front of the caudal keel on the lateral line. The placement of the meat hook is important, as it must not penetrate the usable flesh. The large serrated knife is then used to cut through the pin bones as the half-loin is pulled away from the frame using the meat hook. This results in a very clean cut, leaving almost no waste on the frame. The second half-loin is removed in the same way.

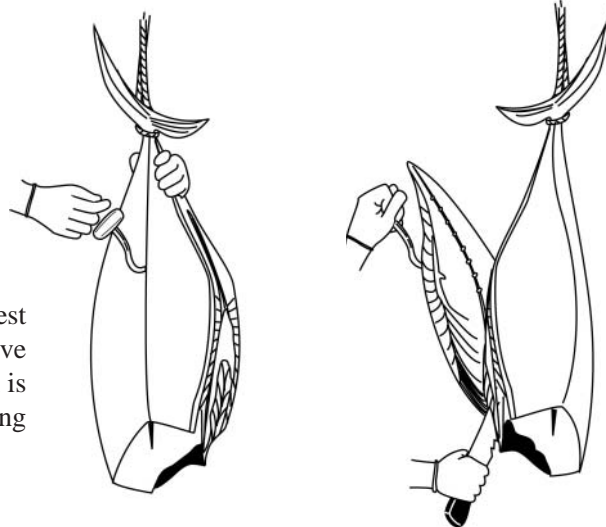

Half-loins are placed on the cutting table for the rest of the processing. A skinning knife is used to remove skin. The skin is removed in sections while the loin is lying flesh side down. This is done to avoid bending the half-loin.



The half-loin is then turned over on the cutting table. The skinning knife is used to cut away the first quarter-loin from the pin bones and bloodline.

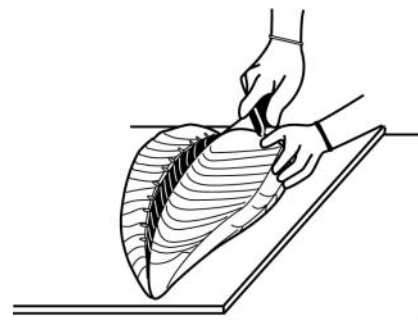

The pin bones and bloodline are then cut away from the second quarter-loin. Rib bones are also removed from the area around the gut cavity. The result is two quarter-loins that usually only require a small amount of trimming to remove remnants of the bloodline.

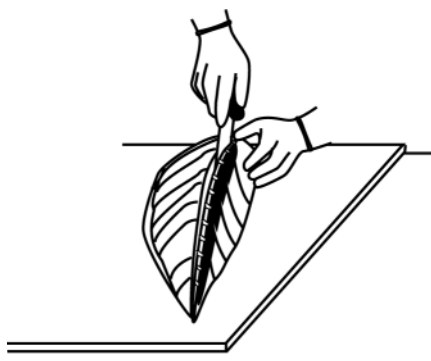

The quarter-loins are then washed and individually wrapped in plastic wrap, ready to be placed in a blast freezer.



Note: The return on this type of processing is about 50 per cent on average (a 20 kg fish would yield around 10 kg of loins). It is wise to examine the markets before deciding to loin or not. If the cannery price for frozen whole fish is half or more of the price being offered by markets for frozen quarter-loins, then it makes no economic sense to loin. On the other hand, if the price being offered for frozen loins is significantly more than twice the price being offered for frozen whole fish, then value can be added by loining at sea.

## F. ON BOARD PRESERVATION: ICING THE CATCH

Basically, there are three ways to chill or preserve fresh fish on board a longline boat: icing, chilled seawater (CSW — sometimes called an ice slurry), and refrigerated seawater (RSW). The type of preservation depends to a certain degree on the longline boat. A boat with one large fish hold would have to use the icing method, while a boat with multiple small fish holds could use either CSW or RSW. Freezers are used to preserve the catch in some locations, with fish frozen whole or processed into loins before freezing.

### Icing fish

Icing is the most difficult method of chilling fish and requires the most skill, but if done properly, produces a superior product. Fish have to be buried in ice as soon as they are cleaned and dressed. The centre bin in the fish hold, often called the slaughter bin, is usually used for the initial chilling. This is called pre-icing. Alternately, fish can be chilled in an ice slurry before icing. It takes many hours to chill the core of a large fish to 0°C. Fish are usually pre-iced overnight. The bins are usually made with removable pound boards, so that sections of the fish hold can be partitioned off as the hold is filled.

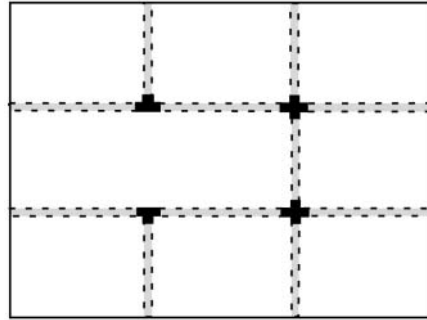

*Top view of a fish hold with removable pound boards*



The condition of the ice can affect the quality of the fish. Flake ice and shell ice both tend to freeze into clumps after several days. Before fish are buried, all ice has to be chopped into fine pieces. Large clumps or chunks of ice can leave dents and bruises on the fish.

A bed of soft ice several centimetres thick should be made in the bottom of the hold. This is called the starting layer. The thickness of the starting layer depends on the insulating properties of the fish hold and on the trip duration. Experience is the best teacher in this case, and each vessel is a little bit different. Fish are first laid out on the starting layer in a fore and aft orientation on their sides, usually with the heads pointing forward. Finely chopped ice is then shovelled over the fish.

The fish are then turned so that the backs are up and bellies down. Large fish can be turned easily. The tail is grabbed with both hands and the fish is twisted into an upright position. As the fish are turned, some ice will fall under the fish along the sides. This ice will prop the fish up while they are covered with more finely chopped ice.

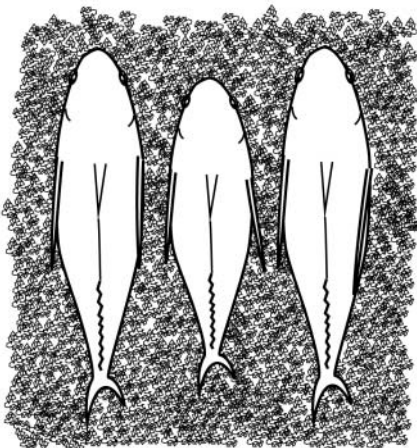
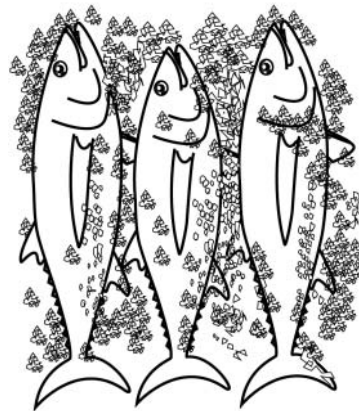

All air pockets should be filled with ice. Fish should not touch each other or the sides of the fish hold. There should be one or two cm of ice between each fish. Heads and fins can touch but not the body trunks. Finally, there should be four or five cm of ice over the layer of fish before another layer of fish is made. Usually on the pre-icing, only one or two layers of fish are made.

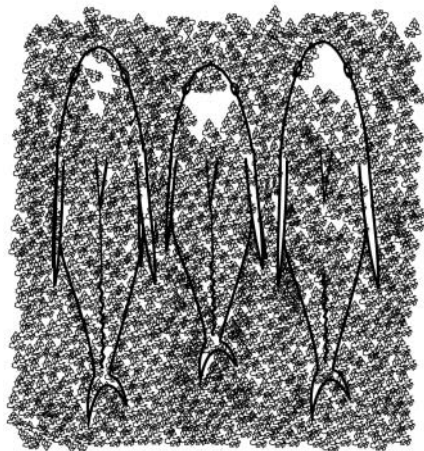

As the fish cools, ice melts and air pockets, called igloos, form around the fish. These air pockets must be removed or the fish will warm up and possibly move around, causing scale loss and bruising.

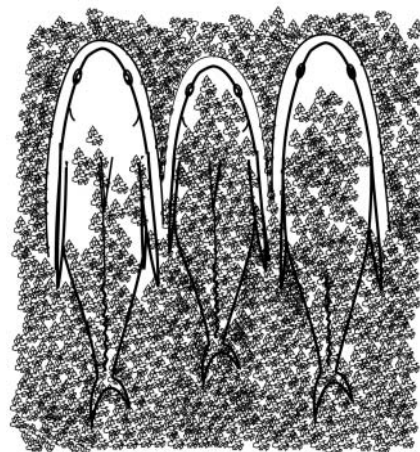

*Igloos forming around fish*

There are two ways to remove the igloos from around fish. The igloos can be broken up with a wooden stick or a shovel handle, and ice repacked around the fish. This does not work too well if the fish are already in several layers.

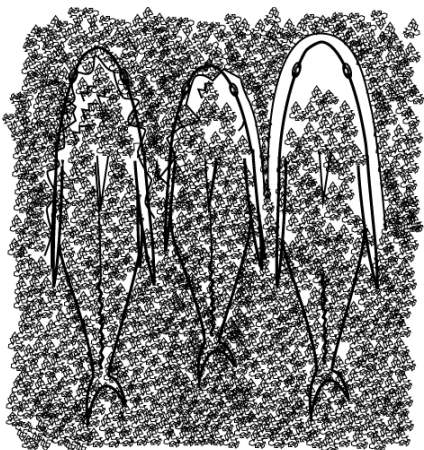

*Breaking up igloos*

The alternative is to dig the fish out of the slaughter bin and rebury them in another bin. In either case the fish have to be iced twice. After the fish are reburied, they require no more handling, as no more air pockets will form. Small fish can be buried four or five layers deep, larger fish up to three layers deep. Large fish should be put in the bottom layer and smaller fish on top. The same thickness of ice around the fish should be used as in the pre-icing. Sharks should not be buried in the same bin with other species, especially sashimi tunas.

The buried fish should be checked at least once a day. Any melt water should be pumped out of the fish hold and the top layer of fish should get a new cap layer of ice when necessary. There should be no heads or bodies sticking out through the ice — tails and fins are okay, though.

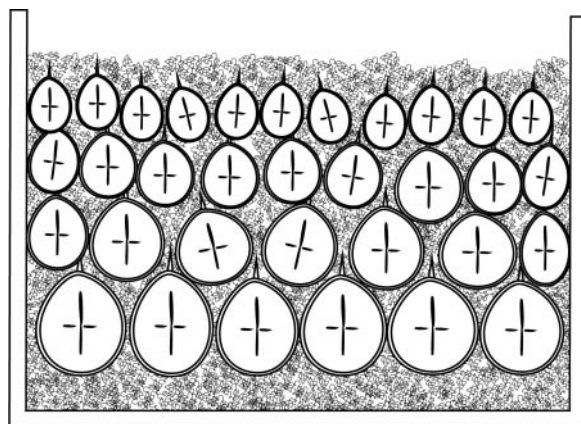

*Layers of fish — large fish on bottom and small fish on top*



*Adding ice*

## G. ON BOARD PRESERVATION: CSW AND RSW

By contrast to the icing method, preserving fish in CSW or RSW systems is easy and fast. After a fish has been cleaned and dressed, and wrapped in a mutton cloth or plastic body bag, it is simply immersed in the tank with the chilled seawater or refrigerated seawater.

CSW does require some preparation. Before hauling begins, a tank filled with flake ice must be mixed with seawater. The ice usually freezes into clumps and these must be broken up. The result should be a slurry of ice and seawater in a two-to-one ratio. An ice slurry should have the consistency of wet cement. Fish placed in a slurry will usually be suspended in the slurry to start, and then slowly sink and find their way to the bottom of the tank. As more fish are added and ice melts, more ice will need to be added to the slurry.

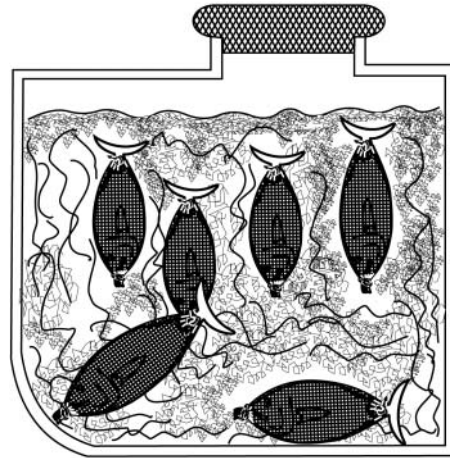

More care must be given to placing fish in an RSW tank so the fish will not get damaged on the sides or bottom of the tank. Usually, a long tail rope is used to gently lower the fish. A floatline or discarded branchline works fine for this. The line is doubled and the resulting loop or bight is wrapped around the tail of the fish but not knotted. The fish is then lowered slowly into the tank until it comes to rest. The tail rope should then slip off of the tail easily so it can be recovered.

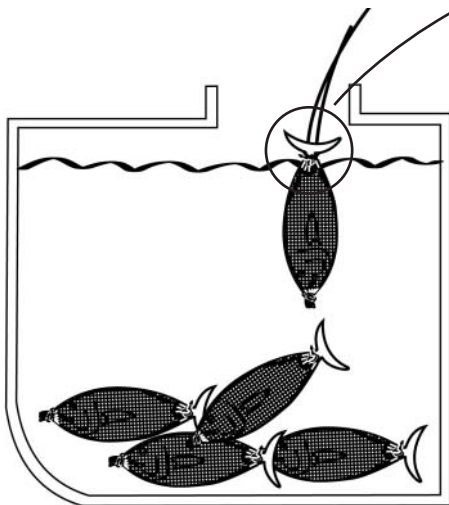
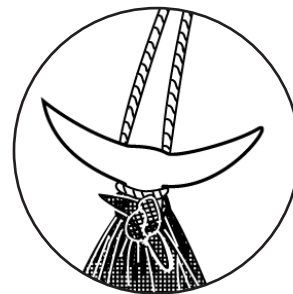

Some CSW and RSW boats suspend the fish vertically in the tank by tail ropes. Other boats have tank baffles so that fish movement is minimised. No further handling is necessary once fish are placed in a CSW or RSW tank.

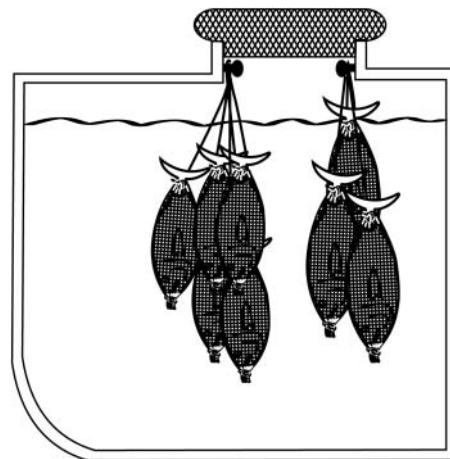

A CSW tank should always have some ice. Preferably the mixture should be stiff enough so that fish do not move around much. The temperature will be close to 0°C if there is ice in the tank. The temperature in RSW systems should be monitored several times per day, either with a built-in temperature gauge or with a hand held thermometer. RSW temperatures should be kept in the range of -0.5° to -1°C (the water in an RSW system is usually a mix of 80 to 90 per cent fresh water and 10 to 20 per cent seawater). A hand held digital probe thermometer is useful for checking RSW tanks and it can also be used to check the core temperature of fish during unloading and processing.

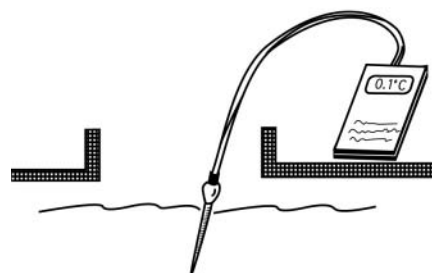

## H. ON BOARD PRESERVATION: FREEZING

Fish, whether whole or loined, should be frozen in a blast (snap) or plate freezer. Some boats have separate freezer holds where fish are stored after initial freezing. Fish are blast or plate frozen down to  $-35^{\circ}\text{C}$  or lower, and are then stored in a separate freezer hold at  $-18^{\circ}\text{C}$  or lower. For cannery fish  $-18^{\circ}\text{C}$  is usually sufficient, but for fish destined for the sashimi markets, colder temperatures are required. Fish have to be maintained at  $-35^{\circ}$  to  $-40^{\circ}\text{C}$ . Some Japanese markets require frozen sashimi to be maintained at ultra-low temperature (ULT) of around  $-65^{\circ}\text{C}$ .

Once the fish or processed loins have been made ready for freezing, they are placed on trays or shelves in the blast freezer. The spacing of the shelves is usually adjustable, to cater to the thickness of the fish or loins being frozen. The fish or loins should not be stacked on each other for freezing.

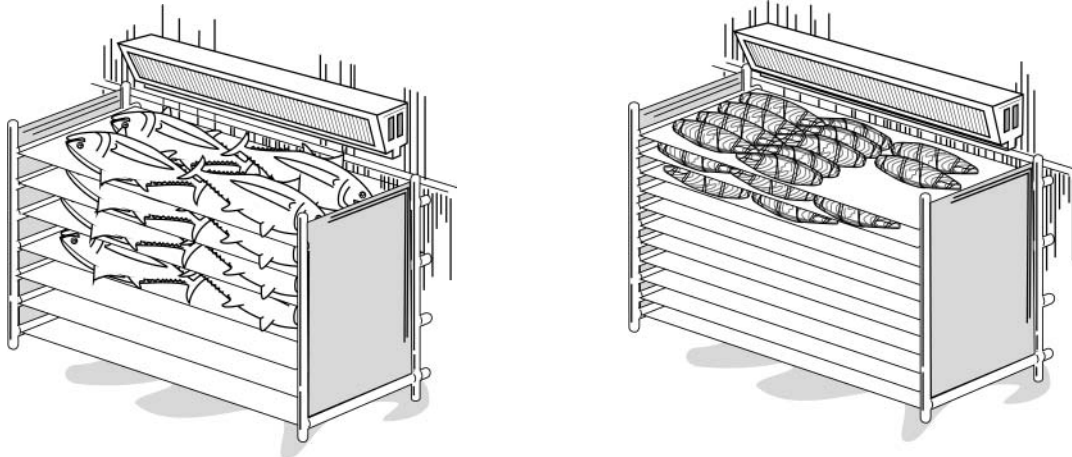

An alternative for freezing whole fish is to hang them from racks so they freeze straight. To do this, each fish has a tail rope, with a meat hook used through the tail rope to secure the fish to a rail. The rack usually has space for several rails, or rows of fish. The meat hooks can slide on the rail, so the fish can be pushed along to pack them in and reduce movement. In some cases there can be two rails, one above the other, to maximise the freezing space.

Once the fish or loins are frozen, they are transferred to a storage freezer and stacked, or stacked in the same blast freezer. Whole fish are generally stacked in rows, alternating with one head in and one head out. Once a row is made across or along the freezer, the next row is stacked on top using the same alternating method. It is best to stack fish of the same size and body shape together to maximise the use of the storage space.

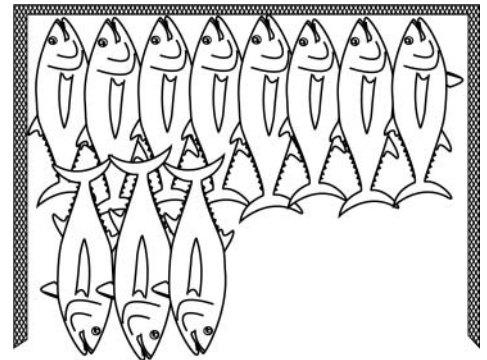

Frozen loins can be stacked similarly to the whole fish, or they can be packed in waxed cardboard cartons to reduce the chance of freezer burn (moisture loss). The cartons are then easily stacked in rows.

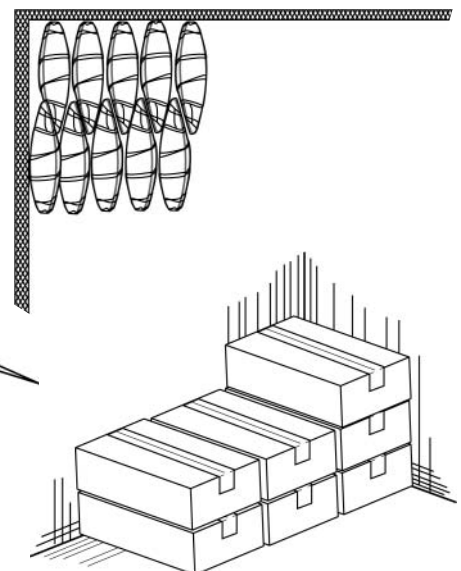
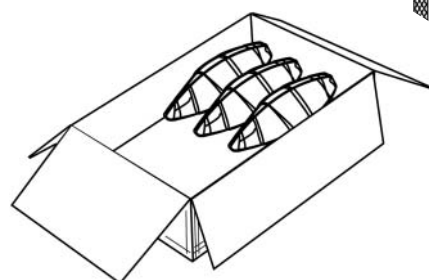
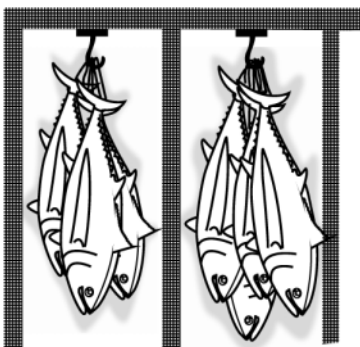

## I. CLEANING AND SANITISING

The working deck of a longliner should be kept clean during fishing operations. Blood, guts and slime should be rinsed away as fish are being cleaned, and should not be allowed to accumulate or dry on the deck or on the carpet or foam pad used for landing fish. Heads, fins, and billfish bills should be thrown overboard as fish are cleaned. At the end of each haul the deck and the carpet should be cleaned and scrubbed, using deck brushes and seawater, but no chemicals. All tools used in fish handling, including gloves, should be cleaned.



After the last set of a trip has been hauled, the working deck and all tools used to handle and process fish on board should be cleaned and sanitised. Cleaning can be done using detergent, copious amounts of seawater, and stiff deck brushes or scouring pads. Sanitising calls for something stronger than detergent. Household bleach mixed with water works well; and there are commercial preparations that work well, too. All blood, slime, scales, and bits of flesh should be scrubbed from the deck and bulwarks around the working deck. Next, every surface should be sanitised with a mixture of household bleach and water. Finally, all surfaces should be rinsed thoroughly to remove all trace of chemicals.

After the vessel reaches port and the fish have been unloaded, the same cleaning and sanitising process should be done to the fish hold and all bin boards (pound boards). Carpets and foam pads used for landing fish are often difficult to clean. They should be discarded if they cannot be sanitised.



If freezers are used to preserve the catch, these should also be scrubbed out when they are turned off, especially the blast freezer where blood or juices may have dripped out of the fish during the freezing process.